



C09-M-307/C09-MET-307

3251

BOARD DIPLOMA EXAMINATION, (C-09)

OCT/NOV—2017

DME—THIRD SEMESTER EXAMINATION

MACHINE DRAWING

Time : 3 hours]

PART—A

5×4=20

- Instructions :** (1) Answer **all** questions.
(2) Each question carries **five** marks.
(3) Answers should be neat and clear with all the necessary dimensions.
(4) All dimensions are in mm.
1. Draw the front view and right-side view of hexagonal headed bolt with proportionate dimensions. Assume diameter of bolt as 30 mm and length as 100 mm. 3+2
 2. Draw the following with standard proportions : 2½×2=5
 - (a) Capstan nut
 - (b) Wing nut
 3. Draw the symbols for the following pipe fittings : 1×5=5
 - (a) Globe valve
 - (b) Check valve
 - (c) Reducer
 - (d) Union joint
 - (e) Gate valve

4. Draw the symbols for the following types of weld : 1×5=5
- (a) Spot weld
 - (b) Steam weld
 - (c) Single V-butt weld
 - (d) Fillet weld
 - (e) Plug weld

PART—B

40

- Instructions :** (1) Answer *any one* question.
 (2) All dimensions are in mm.
 (3) Assume missing data suitably.

5. Assemble the parts of the universal coupling as shown in Fig. 1.
- (a) Full-sectional front view 20+3 marks for dimensioning
 - (b) Left-side view 15+2 marks for dimensioning

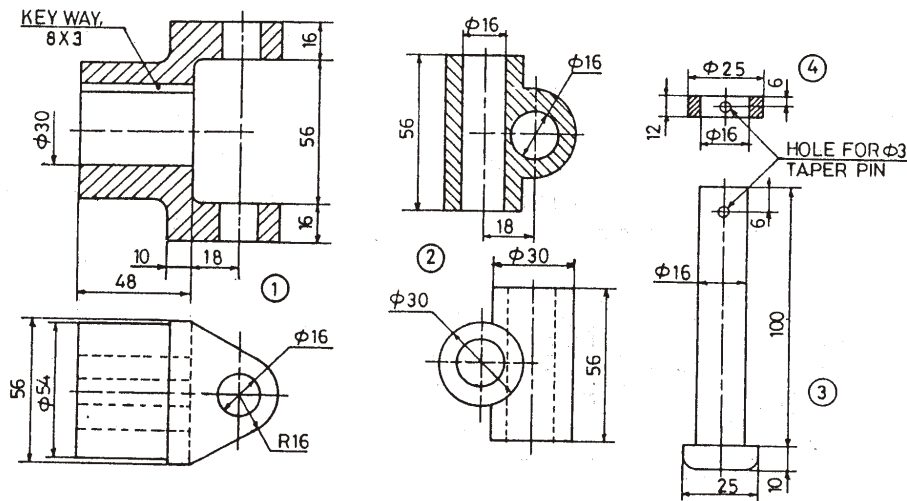

Parts list

No.	Name	Matl	Qty
1	Fork	MS	2
2	Centre block	MS	1
3	Pin	MS	2
4	Collar	MS	2

Fig. 1

6. Assemble the parts of the screw jack as shown in Fig. 2.

(a) Half-sectional front view with right half in section

23+3 marks for dimensioning

(b) Top view

12+2 marks for dimensioning

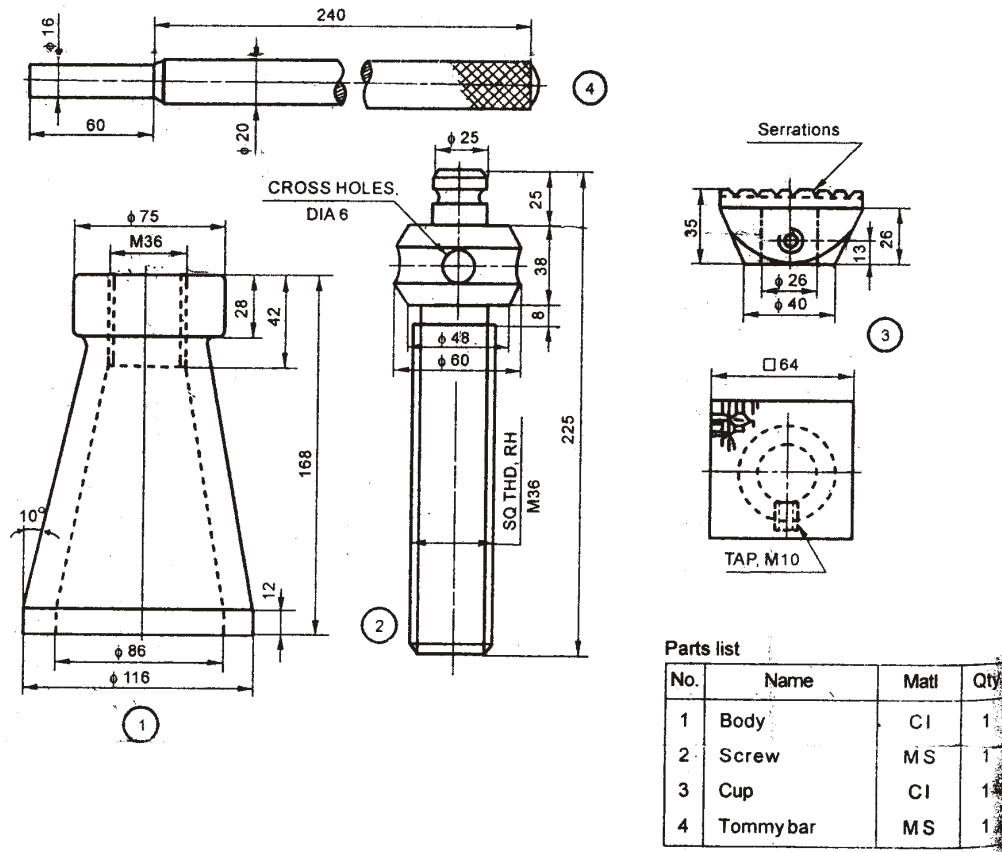

Fig. 2
