



C14-M-405

4481

BOARD DIPLOMA EXAMINATION, (C-14)

MARCH/APRIL—2017

DME—FOURTH SEMESTER EXAMINATION

FLUID MECHANICS AND HYDRAULIC MACHINERY

Time: 3 hours ]

[ Total Marks : 80

**PART—A**

3×10=30

**Instructions** : (1) Answer **all** questions.

(2) Each question carries **three** marks.

(3) Answers should be brief and straight to the point and shall not exceed *five* simple sentences.

1. Define specific gravity and capillarity. 1½+1½
2. Define the terms (a) atmospheric pressure, (b) gauge pressure and (c) absolute pressure. 1+1+1
3. Define the terms (a) uniform flow and (b) irrotational flow. 1½+1½
4. State any three assumptions made in Bernoulli's equation. 1+1+1
5. A pipe of 1.5 km long of diameter 1.2 m with a velocity of 1 m/sec. Determine the head loss due to friction. [Take C = 65] 3
6. Write a short note on syphon system. 3
7. Derive the expression for the force exerted by the jet on stationary inclined flat plate. 3

8. Define specific speed of turbine. 3
9. Classify water turbines according to the direction of flow of water in the runner giving one example for each type. 3
10. Define the heads (a) static head and (b) manometric head of a centrifugal pump.  $1\frac{1}{2}+1\frac{1}{2}$

**PART—B**

10×5=50

**Instructions :** (1) Answer any **five** questions.

(2) Each question carries **ten** marks.

(3) Answers should be comprehensive and the criterion for valuation is the content but not the length of the answer.

11. An inverted differential manometer having an oil of specific gravity 0.8 was connected to pipes A and B carrying water under pressure as shown in the figure :

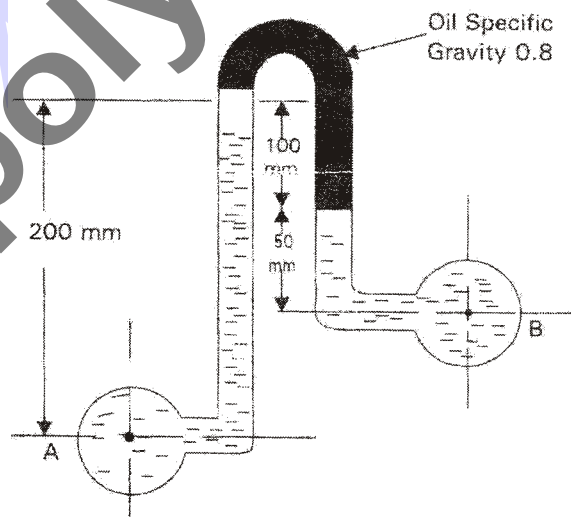

Determine the pressure in the pipe B in terms of kPa, if the manometer reads as shown above the figure. [Take pressure in the pipe A as 14.71 kPa]

10

12. (a) State Bernoulli's equation and explain each term in it. 5
- (b) Water is flowing through a tapered pipe having end diameters of 150 mm and 75 mm respectively. Find the discharge at the larger end and at the smaller end, if the velocity of water at the larger end is 2.5 m/sec. 5
13. Two reservoirs are connected by a straight pipe 1.6 km long for the first half of its length it has 160 mm diameter and then suddenly reduced to 80 mm. The water level in the two reservoirs differ by 30 m. Determine the rate of flow in liters/min. [Take  $f = 0.01$ ] Neglect minor losses. 10
14. Derive the followings expressions for force of jet on series of moving plates fixed on the rim of wheel : (a) force exerted by the jet, (b) work done by the jet, (c) efficiency of the jet and (d) condition for maximum efficiency of the jet. 10
15. (a) A jet of water of 10 cm diameter strikes a flat plate normally with a velocity of 15 m/sec. The plate is moving with a velocity of 6 m/sec in the direction of the jet and away from the jet. Calculate (i) the force in the direction of jet and (ii) the force normal to the plate. 5
- (b) Draw a neat sketch of Pelton wheel and explain its working. 5
16. A Kaplan turbine runner has an outer diameter 3.5 m and hub diameter 1.75 m and develops 11772 kW power. When running at 68 r.p.m. under a head of 20 m. The hydraulic efficiency is 88% and overall efficiency is 84%. Find the discharge through the turbine and guide blade angle at inlet. 10
17. A single-acting single-cylinder reciprocating pump has a plunger diameter 600 mm, stroke 360 mm, speed 75 r.p.m., static lift 12 meters and discharge 6870 liters/min. Determine (a) coefficient of discharge, (b) slip and (c) power required, if pump efficiency is 80%. 10
18. Explain the working of submersible pump with a neat sketch. 10

\*\*\*