



c14-c-403

4426

BOARD DIPLOMA EXAMINATION, (C-14)
MARCH/APRIL—2017
DCE—FOURTH SEMESTER EXAMINATION
QUANTITY SURVEYING—I

Time : 3 hours]

[Total Marks : 80

PART—A

3×10=30

- Instructions :** (1) Answer **all** questions.
(2) Each question carries **three** marks.
(3) Answers should be brief and straight to the point and shall not exceed *five* simple sentences.
(4) Assume any missing data suitably.

1. State the units of the following items :

- (a) Earthwork excavation
(b) Brick masonry
(c) VRCC for columns
(d) Plastering

2. Mention any four rules for measurement of civil works.

3. A canal is proposed to be formed as shown in Fig. 1 below. Calculate lead and lift :

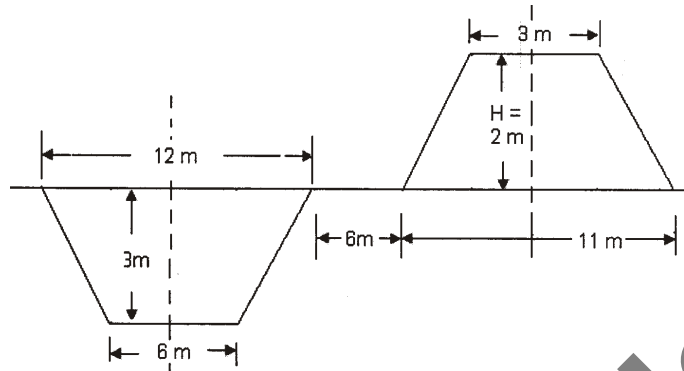

Fig. 1

4. Explain trapezoidal rule and prismoidal rule with usual notations.

5. The details of road of 1 km length, AB are given below :

Depth of embankment at $A = 1$ m
 Depth of embankment at $B = 2$ m
 Side slopes of a road = 1 : 1
 Width of road at top = 8 m

Calculate the volume of earthwork by—

- (a) mid-sectional area method;
 (b) mean sectional area method.

6. Neatly tabulate formats of detailed estimate and abstract estimate separately.

7. State any two purposes of preparing approximate estimate.

8. A parapet wall is to be constructed with a thickness of 120 mm over a rectangular building of 10 m × 12 m having wall thickness 300 mm. Calculate the quantity of brickwork required for the parapet, if the height of the parapet is 600 mm.

9. Calculate the quantity of cement concrete (1:1½:3) required for RCC lintels over doors and windows of a residential building. There are 6 doors of size 1.1 m×2.10 m and 8 windows of size 1.1 m×1.8 m. Thickness of wall is 230 mm and thickness of lintel is 100 mm and a bearing on either side of doors and windows is 150 mm.
10. For the specification shown in Fig. 2 below, what will be the length of hipped rafter? The rise of hipped roof is 1/3 span :

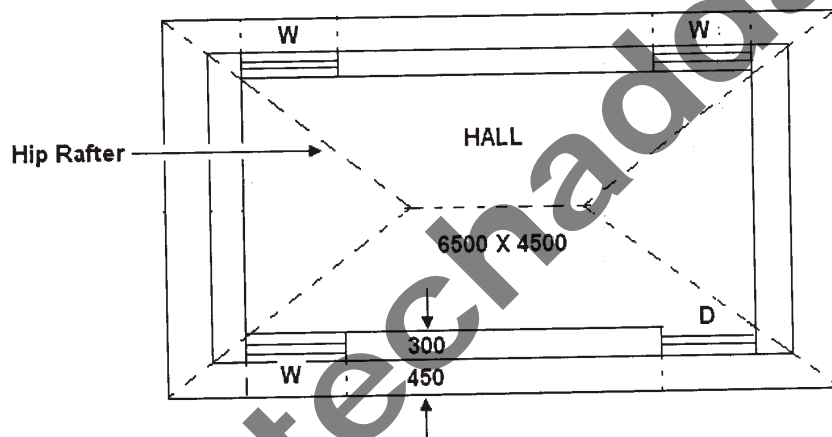

Fig. 2

PART—B

10×5=50

- Instructions:** (1) Answer any **five** questions.
 (2) Each question carries **ten** marks.
 (3) Answers should be comprehensive and the criterion for valuation is the content but not the length of the answer.

11. (a) Mention any four duties of quantity surveyor or estimator.
 (b) What is meant by specification? State its types and necessity.

12. A road is proposed to be constructed in embankment with the following data :

Formation width of road = 8 m
Side slopes in embankment = 2 : 1

The ground levels along the centre line of the road are given below :

RL of the ground (in m)	98.2	97.8	98.0	98.4	98.5	98.3	98.9
Chainage (in m)	0	30	60	90	120	150	180

The formation level may be taken as 100 m constant for 0 m to 180 m chainages. Calculate the quantity of earthwork by (a) trapezoidal formula and (b) prismoidal formula.

13. Calculate the live and dead storage of a reservoir with the following data using (a) trapezoidal formula and (b) prismoidal formula :

Sl. No.	Level (m)	Area (m ²)	Particulars
1	100	2400	Bed level
2	105	2800	—
3	110	3700	Sill level
4	115	5400	—
5	120	8800	—
6	125	12600	FTL
7	130	27000	MWL

14. Prepare a rough estimate of a proposed commercial complex in the corporation limits for the following :

Plinth area = ₹ 400 sq.m/floor
Height of each storey = 3 m
No. of stories = G + 5 floors
Cubic content rate = ₹ 3,000 per cubic m

Provide the following provisions as percentage of building cost :

- (1) WS and sanitary arrangements—8%
- (2) Electrification—6%
- (3) Fluctuation of rates—5%
- (4) Contractors profit—10%
- (5) PS and contingencies—3%

15. Explain the methods of preparing approximate estimates.

16. Calculate the quantity of steel required for the steel struss as shown in Fig. 3 below :

- (a) Main members at 56 N/m
- (b) Struts at 45 N/m

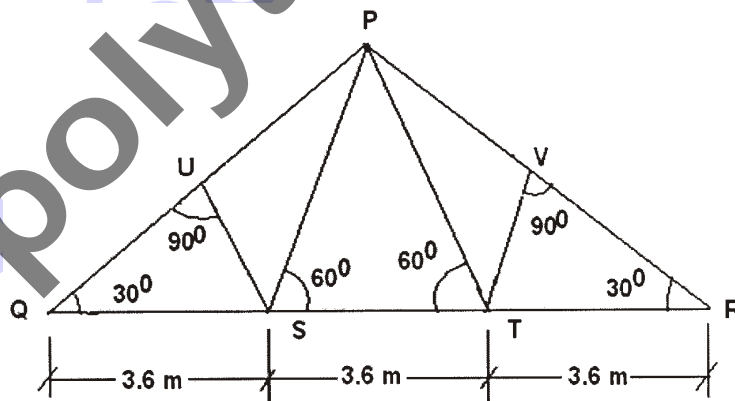

Fig. 3

17. Prepare the detailed estimate for the following items of work from the plan and section shown in the Fig. 4 below :

- (a) Earthwork excavation for foundation

(b) Plastering in CM (1:4) for external walls including parapet without deductions

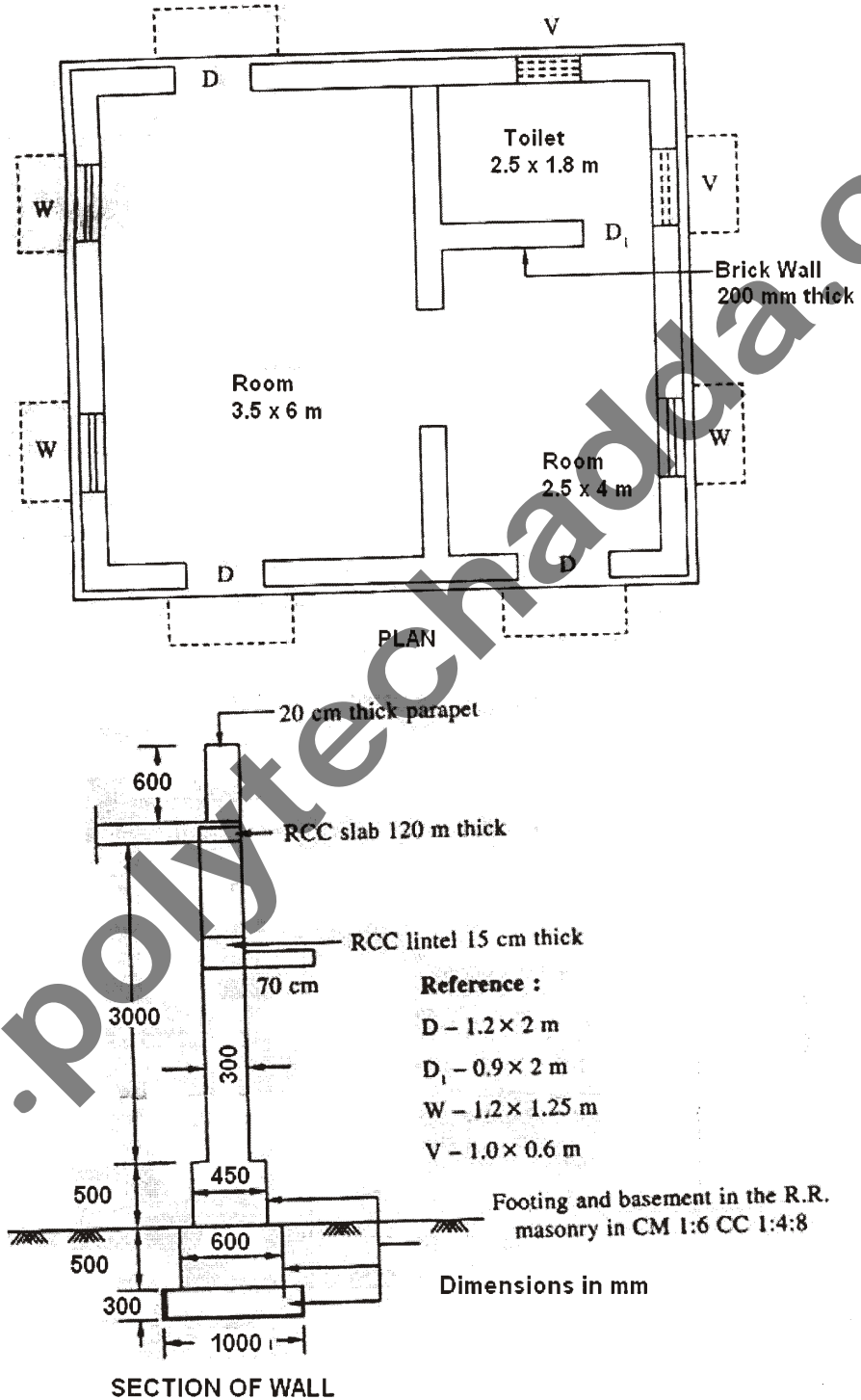

Fig. 4

18. Prepare the detailed estimate for the following items of work shown in Fig. 5 below :

- (a) RR masonry in footings
- (b) Brick masonry in CM (1:6) for superstructure excluding parapet and without deduction for doors and windows and lintels
- (c) RCC roof slab (1:2:4) 100 mm thick

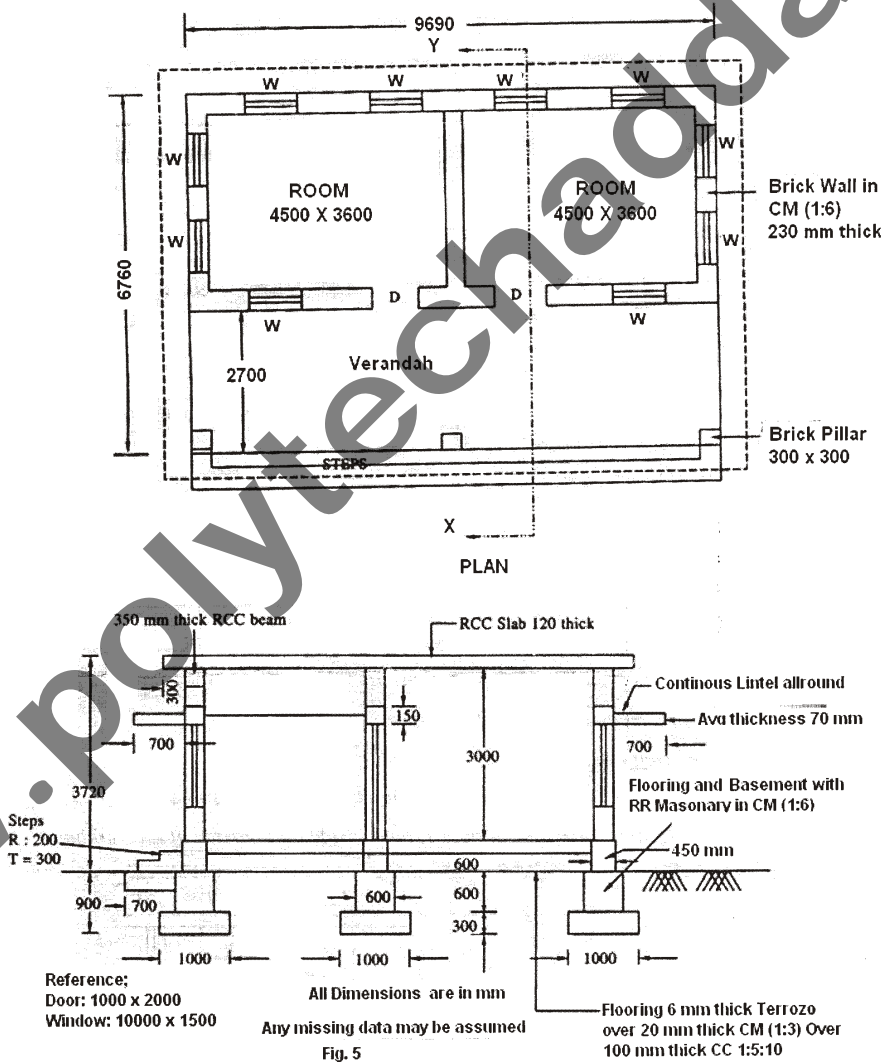

Fig. 5
