



C14-M-407

4483

BOARD DIPLOMA EXAMINATION, (C-14)
OCT/NOV—2017
DME—FOURTH SEMESTER EXAMINATION
PRODUCTION DRAWING PRACTICE

Time : 3 hours]

[Total Marks : 60

PART—A

5×4=20

- Instructions** : (1) Answer **all** questions.
(2) Each question carries **five** marks.
(3) Draw the following neatly with proportionate dimensions.
(4) Use of production drawing tables is allowed.
- Determine the limit dimensions for a clearance fit between the mating parts having nominal diameter of 50 mm, providing a minimum clearance of 0.1 mm, with the tolerance of the hole as 0.02 mm and that of the shaft 0.03 mm. Follow shaft basis system.
 - What are the surface roughness grade number and roughness grade symbol for surfaces with roughness value 50 μ m, 12.5 μ m, 1.6 μ m, 0.2 μ m, 0.025 μ m.
 - Write the meaning of the following designations :
 - FeE 460
 - 25Cr4Mo2G
 - Square bolt M 12 × 50 N, IS : 2585
 - Castle nut M 20, IS : 2232-B-4
 - Stud AM 10×40, IS 1862-P-4.6
 - How are ammonia prints prepared?

Instructions : (1) Answer *any one* question.
 (2) Each question carries **forty** marks.

5. Study the given assembly drawing of knuckle joint given in the fig. 1. 20+8+3+4+5

- (a) Draw the component drawings for all parts
- (b) Prepare the process sheet for the pin
- (c) Prepare bill of material
- (d) Indicate the recommended surface roughness values on all the parts.
- (e) Indicate suitable tolerances wherever needed. Mention the type of fit between the mating parts (i) Pin and fork end (ii) Fork end and eye end.

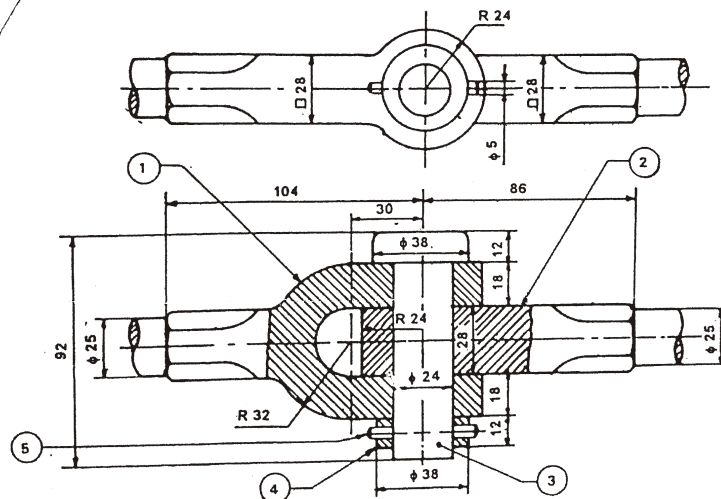

Knuckle Joint Parts List

Part No	Name
1	Fork End
2	Eye End
3	Pin
4	Coller
5	Taper Pin

Fig. 1 (Knuckle Joint)

6. Study the given assembly drawing of revolving centre given in the Fig. 2 : 20+8+3+4+5

(a) Draw the component drawings for parts 1, 2, 6, 7 and 8.

(b) Prepare the process sheet for Barrel.

(c) Prepare bill of material.

(d) Indicate the recommended surface roughness values on parts 1, 2, 6 and 7.

(e) Indicate suitable tolerances wherever needed. Mention the type of fit between the mating parts (i) barrel and the sleeve (ii) sleeve and the center.

Revolving Centre Parts List	
Part No.	Name
1.	Centre
2.	Front Cover
3.	Screen
4.	Radial ball bearing
5.	Thrust ball bearing
6.	Barrel
7.	Sleeve
8.	Back Cover

